

1. General Description

The EM74LVC1G10 is a single 3-input NAND gate. Inputs can be driven from either 3.3 V or 5 V devices. This feature allows the use of these devices as translators in mixed 3.3 V and 5 V applications.

Schmitt trigger action at all inputs makes the circuit tolerant of slower input rise and fall time. This device is fully specified for partial power-down applications using I_{OFF} . The I_{OFF} circuitry disables the output, preventing the damaging backflow current through the device when it is powered down.

2. Features and Benefits

- Wide supply voltage range from 1.65 V to 5.5 V
- High noise immunity
- ± 24 mA output drive ($V_{CC} = 3.0$ V)
- CMOS low power dissipation
- Direct interface with TTL levels
- Overvoltage tolerant inputs to 5.5 V
- I_{OFF} circuitry provides partial Power-down mode operation
- Latch-up performance exceeds 100 mA
- Complies with JEDEC standard:
 - JESD8-7 (1.65 V to 1.95 V)
 - JESD8-5 (2.3 V to 2.7 V)
 - JESD8C (2.7 V to 3.6 V)
 - JESD36 (4.5 V to 5.5 V)
- ESD protection:
 - HBM ANSI/ESDA/JEDEC JS-001 Class 3B exceeds 8000 V
 - MM JESD22-A115C Class C exceeds 550 V
 - CDM ANSI/ESDA/JEDEC JS-002 Class C3 exceeds 2000 V
- Multiple package options

3. Ordering Information

Table 1. Ordering information

Type number	Topside marking	Package		Quantity
		Name	Description	
EM74LVC1G10GV	V8YW	SOT23-6L	SOT23 package, 6 pins 2.92 mm × 1.6 mm; 1.25 mm (Max) height	3000
EM74LVC1G10GW	V8YW	SOT363	SOT363 package, 6 pins 2.1 mm × 1.25 mm; 1.1 mm (Max) height	3000
EM74LVC1G10GS	V8	DFN1x1-6L	DFN1×1 package, 6 pins 1 mm × 1 mm; 0.42 mm (Max) height	3000
EM74LVC1G10GM	V8YW	DFN1x1.45-6L	DFN1.45×1 package, 6 pins 1.45 mm × 1 mm; 0.6 mm (Max) height	3000

4. Function Diagram

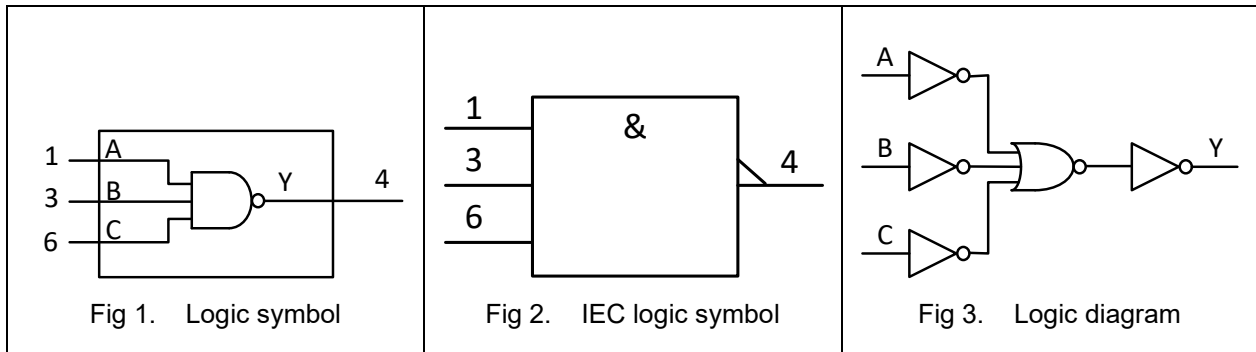

5. Pinning Information

5.1. Pin map

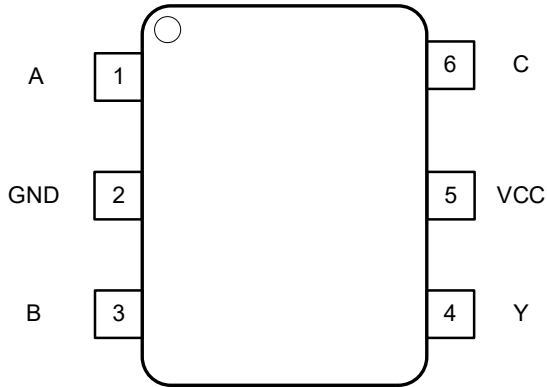

Fig 4. Top view pin configuration SOT23-6 and SOT363

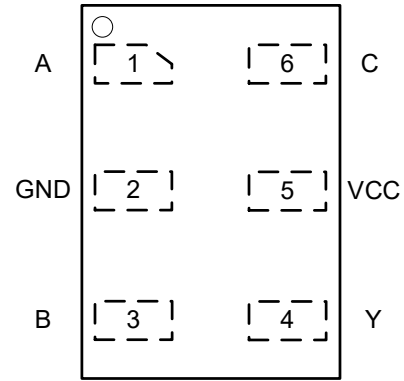

Fig 5. Top view pin configuration DFN6L

5.2. Pin description

Table 2. Pin description

Symbol	Pin	Description
A	1	Data input
GND	2	Ground (0V)
B	3	Data input
Y	4	Data output
VCC	5	Supply voltage
C	6	Data input