

## 1. General Description

---

The EM74LVC2G06 is a dual inverter with open-drain outputs. Inputs can be driven from either 3.3 V or 5 V devices. This feature allows the use of these devices as translators in mixed 3.3 V and 5 V environments. Schmitt-trigger action at all inputs makes the circuit tolerant of slower input rise and fall times. This device is fully specified for partial power down applications using I<sub>OFF</sub>. The I<sub>OFF</sub> circuitry disables the output, preventing the potentially damaging backflow current through the device when it is powered down.

## 2. Features and Benefits

---

- Wide supply voltage range from 1.65 V to 5.5 V
- Overvoltage tolerant inputs to 5.5 V
- High noise immunity
- CMOS low power dissipation
- I<sub>OFF</sub> circuitry provides partial Power-down mode operation
- -24 mA output drive (V<sub>CC</sub> = 3.0 V)
- Latch-up performance exceeds 100 mA
- Direct interface with TTL levels
- Complies with JEDEC standard:
  - JESD8-7 (1.65 V to 1.95 V)
  - JESD8-5 (2.3 V to 2.7 V)
  - JESD8C (2.7 V to 3.6 V)
  - JESD36 (4.5 V to 5.5 V)
- ESD protection:
  - HBM ANSI/ESDA/JEDEC JS-001 Class 3B exceeds 8000 V
  - MM JESD22-A115C Class C exceeds 550 V
  - CDM ANSI/ESDA/JEDEC JS-002 Class C3 exceeds 2000 V
- Multiple package options

### 3. Ordering Information

**Table 1. Ordering information**

Type number	Topside marking	Package		Quantity
		Name	Description	
EM74LVC2G06GV	VZYW	SOT23-6L	SOT23 package, 6 pins 2.92 mm × 1.6 mm; 1.25 mm (Max) height	3000
EM74LVC2G06GW	VZYW	SOT363	SOT363 package, 6 pins 2.1 mm × 1.25 mm; 1.1 mm (Max) height	3000
EM74LVC2G06GS	VZ	DFN1x1-6L	DFN1×1 package, 6 pins 1 mm × 1 mm; 0.42 mm (Max) height	3000
EM74LVC2G06GM	VZYW	DFN1x1.45-6L	DFN1.45×1 package, 6 pins 1.45 mm × 1 mm; 0.6 mm (Max) height	3000

### 4. Function Diagram

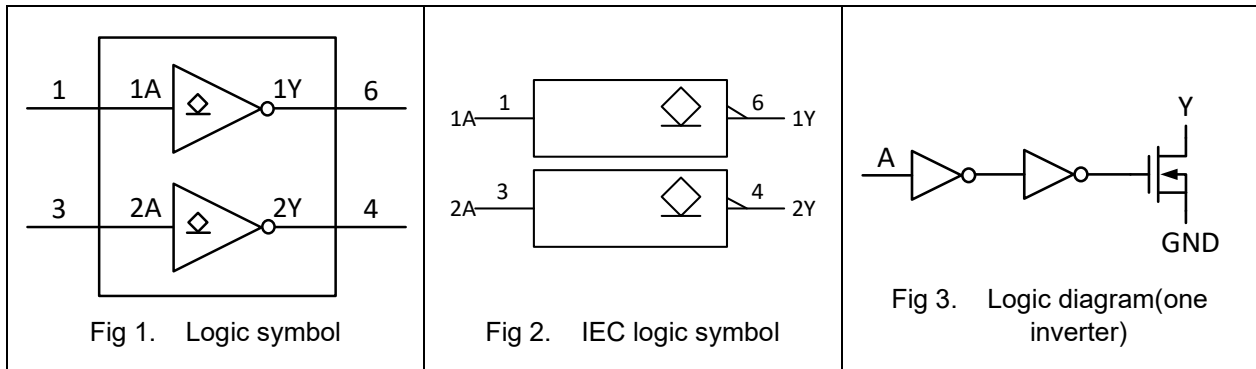

## 5. Pinning Information

### 5.1. Pin map

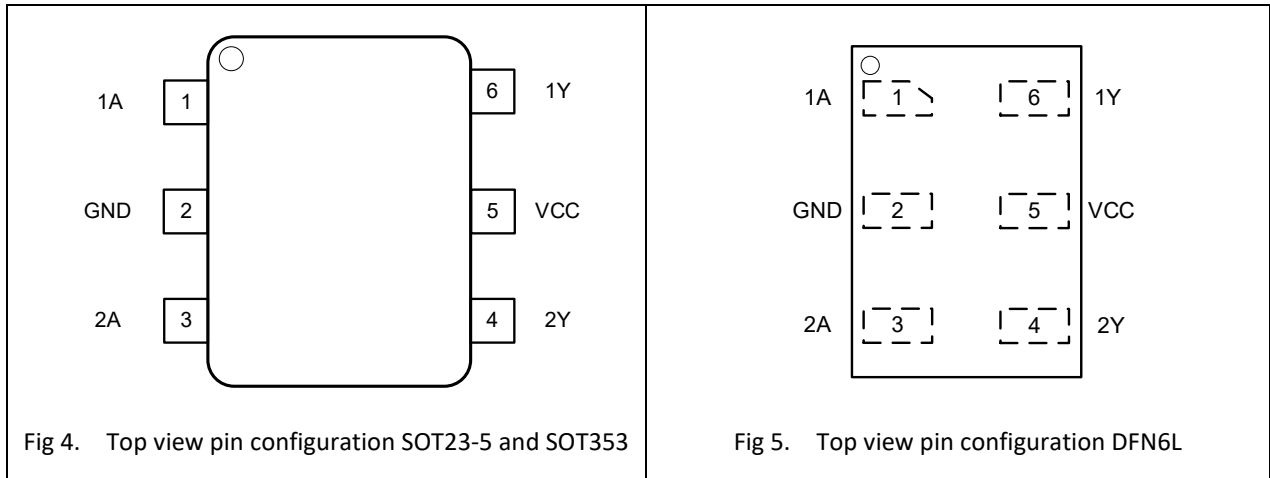

### 5.2. Pin description

Table 2. Pin description

Symbol	Pin	Description
1A	1	Data input
GND	2	Ground (0V)
2A	3	Data input
2Y	4	Data output
VCC	5	Supply voltage
1Y	6	Data output

## 6. Functional Description

Table 3. Function table

H = HIGH voltage level; L = LOW voltage level; Z = high-impedance OFF-state.

Input nA	Output nY
L	Z
H	L