

## 1. General Description

---

The EM74LVC1G240 is a 1-bit inverting buffer/line driver with 3-state output. The device features an output enable  $\overline{OE}$ . A HIGH on  $\overline{OE}$  causes the output to assume a high-impedance OFF-state. Inputs can be driven from either 3.3 V or 5 V devices. This feature allows the use of these devices as translators in mixed 3.3 V and 5 V environments.

Schmitt-trigger action at all inputs makes the circuit tolerant of slower input rise and fall times. This device is fully specified for partial power down applications using  $I_{OFF}$ . The  $I_{OFF}$  circuitry disables the output, preventing the potentially damaging backflow current through the device when it is powered down.

## 2. Features and Benefits

---

- Wide supply voltage range from 1.65 V to 5.5 V
- Inputs accept voltages up to 5 V
- High noise immunity
- CMOS low power dissipation
- $\pm 24$  mA output drive ( $V_{CC} = 3.0$  V)
- Latch-up performance exceeds 100 mA
- Direct interface with TTL levels
- Complies with JEDEC standard:
  - JESD8-7 (1.65 V to 1.95 V)
  - JESD8-5 (2.3 V to 2.7 V)
  - JESD8-B/JESD36 (2.7 V to 3.6 V)
- ESD protection:
  - HBM ANSI/ESDA/JEDEC JS-001 Class 3B exceeds 8000 V
  - MM JESD22-A115C Class C exceeds 550 V
  - CDM ANSI/ESDA/JEDEC JS-002 Class C3 exceeds 2000 V
- Multiple package options

## EM74LVC1G240

Single inverting buffer/line driver; 3-state

### 3. Ordering Information

Table 1. Ordering information

Type number	Topside marking	Package		Quantity
		Name	Description	
EM74LVC1G240GV	VRYW	SOT23-5L	SOT23 package, 5 pins 2.92 mm × 1.6 mm; 1.25 mm (Max) height	3000
EM74LVC1G240GW	VRYW	SOT353	SOT353 package, 5 pins 2.1 mm × 1.25 mm; 1.1 mm (Max) height	3000
EM74LVC1G240GS	VR	DFN1x1-6L	DFN1×1 package, 6 pins 1 mm × 1 mm; 0.42 mm (Max) height	3000
EM74LVC1G240GM	VRYW	DFN1x1.45-6L	DFN1.45×1 package, 6 pins 1.45 mm × 1 mm; 0.6 mm (Max) height	3000
EM74LVC1G240GX	VR	DFN0.8x0.8-4L	DFN0.8×0.8 package, 5 pins 0.8 mm × 0.8 mm; 0.4 mm (Max) height	3000

### 4. Function Diagram

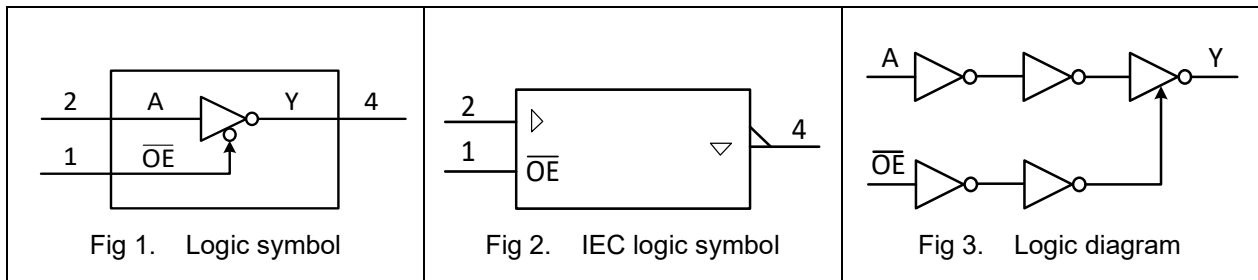

## 5. Pinning Information

### 5.1. Pin map

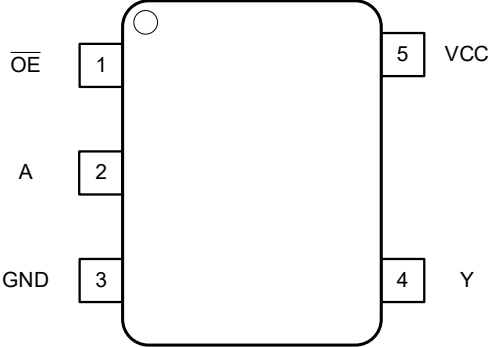
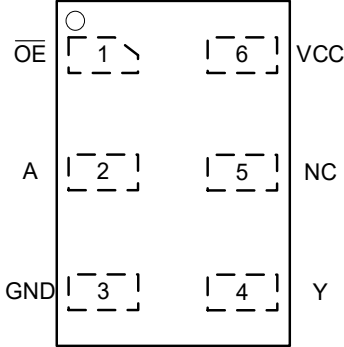
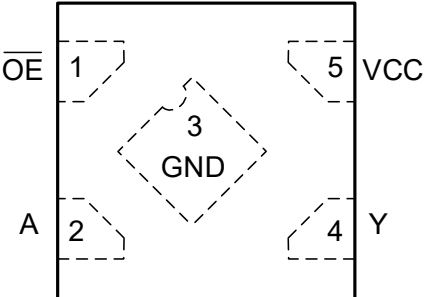
 <p>Fig 4. Top view pin configuration SOT23-5 and SOT353</p>	 <p>Fig 5. Top view pin configuration DFN6L</p>
 <p>Fig 6. Top view pin configuration DFN4L</p>	

### 5.2. Pin description

Table 2. Pin description

Symbol	Pin		Description
	SOT23-5, SOT353 and DFN4L	DFN6L	
$\overline{OE}$	1	1	Output enable input
A	2	2	Data input
GND	3	3	Ground (0V)
Y	4	4	Data output
NC	-	5	Not connected
VCC	5	6	Supply voltage