

## 1. General Description

---

The EM74LVC2GU04 is a dual unbuffered inverter. Inputs can be driven from either 3.3 V or 5 V devices. This feature allows the use of these devices as translators in mixed 3.3 V and 5 V environments.

## 2. Features and Benefits

---

- Wide supply voltage range from 1.65 V to 5.5 V
- Overvoltage tolerant inputs to 5.5 V
- High noise immunity
- $\pm 24$  mA output drive (VCC = 3.0 V)
- CMOS low power dissipation
- Latch-up performance exceeds 100 mA
- ESD protection:
  - HBM ANSI/ESDA/JEDEC JS-001 Class 3B exceeds 8000 V
  - MM JESD22-A115C Class C exceeds 550 V
  - CDM ANSI/ESDA/JEDEC JS-002 Class C3 exceeds 2000 V
- Multiple package options

### 3. Ordering Information

**Table 1. Ordering information**

Type number	Topside marking	Package		Quantity
		Name	Description	
EM74LVC2GU04GV	VrYW	SOT23-6L	SOT23 package, 6 pins 2.92 mm × 1.6 mm; 1.25 mm (Max) height	3000
EM74LVC2GU04GW	VrYW	SOT363	SOT363 package, 6 pins 2.1 mm × 1.25 mm; 1.1 mm (Max) height	3000
EM74LVC2GU04GS	Vr	DFN1x1-6L	DFN1×1 package, 6 pins 1 mm × 1 mm; 0.42 mm (Max) height	3000
EM74LVC2GU04GM	VrYW	DFN1x1.45-6L	DFN1.45×1 package, 6 pins 1.45 mm × 1 mm; 0.6 mm (Max) height	3000

### 4. Function Diagram

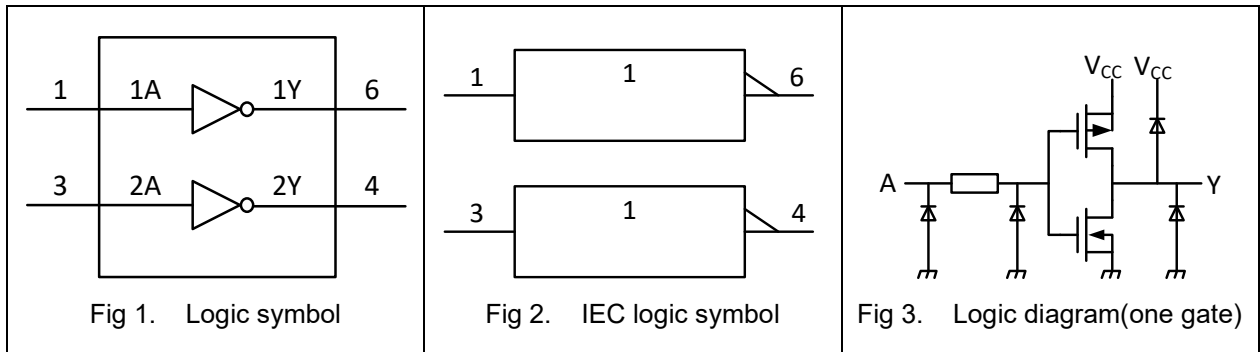

## 5. Pinning Information

### 5.1. Pin map

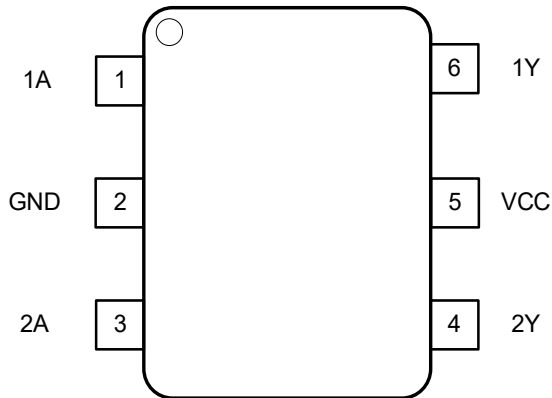

Fig 4. Top view pin configuration SOT23-6 and SOT363

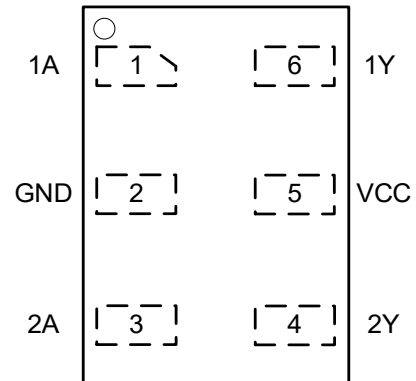

Fig 5. Top view pin configuration DFN6L

### 5.2. Pin description

Table 2. Pin description

Symbol	Pin	Description
1A	1	Data input
GND	2	Ground (0V)
2A	3	Data input
2Y	4	Data output
VCC	5	Supply voltage
1Y	6	Data output

## 6. Functional Description

Table 3. Function table

H = HIGH voltage level; L = LOW voltage level.

Input	Output
nA	nY
L	H
H	L