

1. General Description

The EM74HC04; EM74HCT04 is a hex inverter. Inputs include clamp diodes. This enables the use of current limiting resistors to interface inputs to voltages in excess of V_{CC} .

2. Features and Benefits

- Wide supply voltage range from 2.0 V to 6.0 V
- High noise immunity
- CMOS low power dissipation
- Latch-up performance exceeds 250 mA
- Complies with JEDEC standards:
 - JESD8C (2.7 V to 3.6 V)
 - JESD7A (2.0 V to 6.0 V)
- Input levels:
 - For EM74HC04: CMOS level
 - For EM74HCT04: TTL level
- ESD protection:
 - HBM ANSI/ESDA/JEDEC JS-001 Class 2 exceeds 3500 V
 - CDM ANSI/ESDA/JEDEC JS-002 Class C3 exceeds 2000 V
- Multiple package options

3. Ordering Information

Table 1. Ordering information

Type number	Package		
	Name	Description	Quantity
EM74HC04D	SOP-14L	plastic small outline package; 14 leads; body width 3.9 mm	3000
EM74HCT04D			
EM74HC04PW	TSSOP-14L	plastic thin shrink small outline package; 14 leads; body width 4.4 mm	3000
EM74HCT04PW			

4. Function Diagram

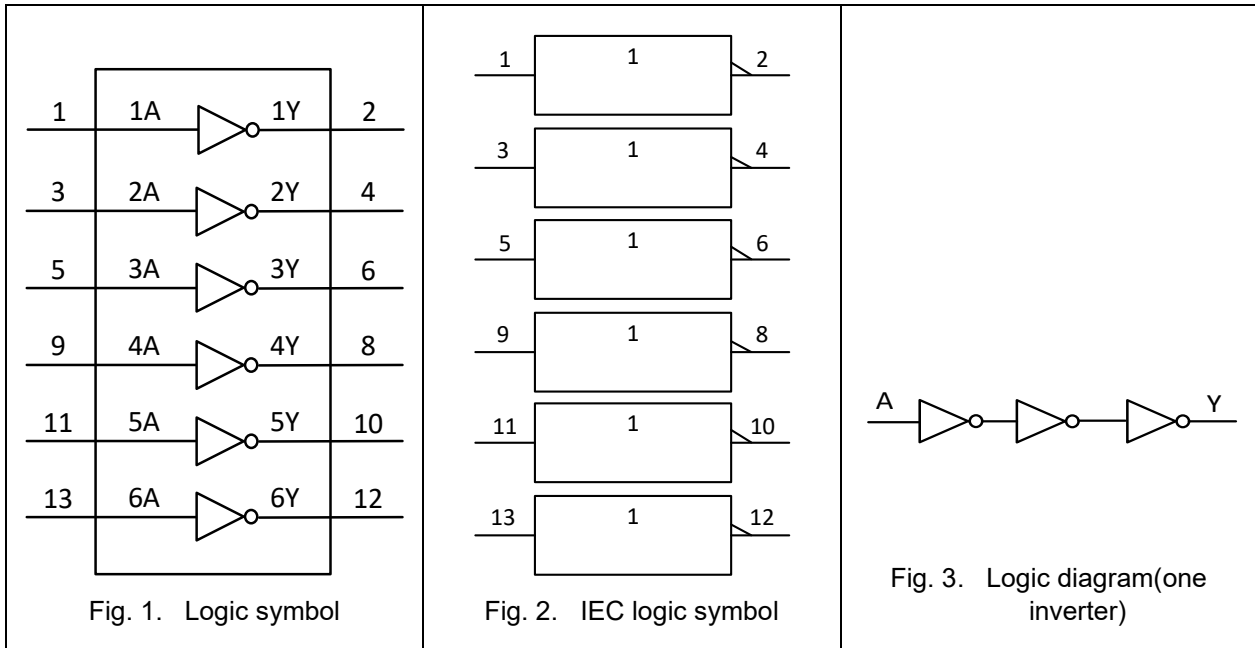

5. Pinning Information

5.1. Pinning

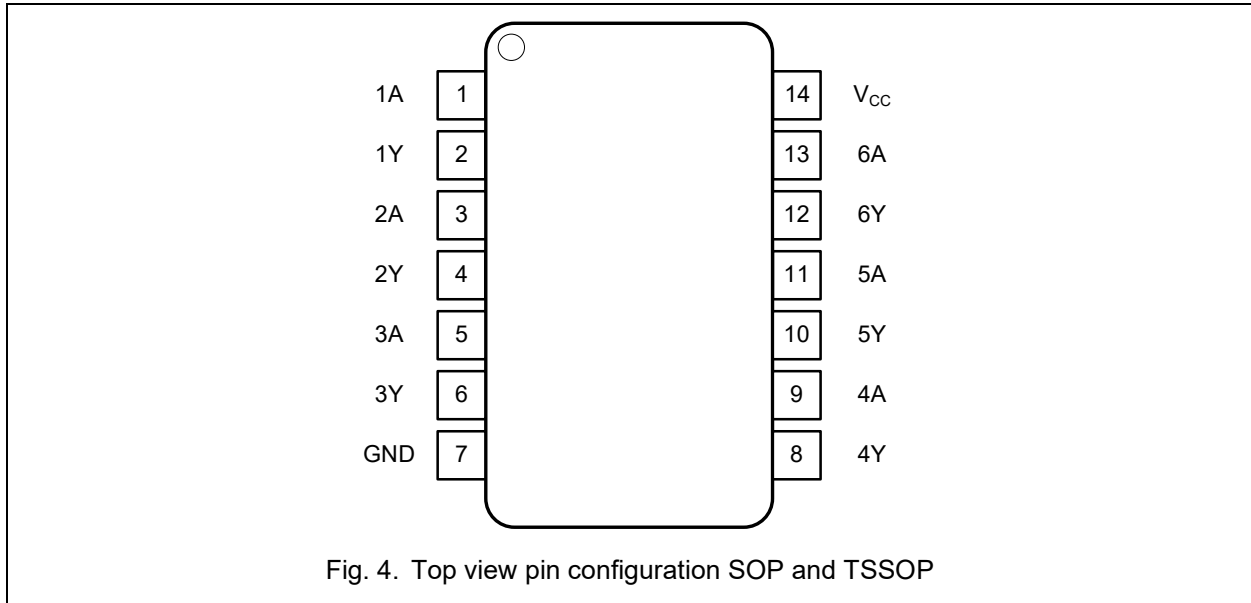

5.2. Pin description

Table 2. Pin description

Symbol	Pin	Description
1A, 2A, 3A, 4A, 5A, 6A	1, 3, 5, 9, 11, 13	Data input
1Y, 2Y, 3Y, 4Y, 5Y, 6Y	2, 4, 6, 8, 10, 12	Data output
GND	7	Ground (0V)
V _{cc}	14	Supply voltage

6. Functional Description

Table 3. Function table

H = HIGH voltage level; L = LOW voltage level.

Control	Output
nA	nY
L	H
H	L