

1. General Description

The EM74HC4002; EM74HCT4002 is a dual 4-input NOR gate. Inputs include clamp diodes. This enables the use of current limiting resistors to interface inputs to voltages in excess of V_{CC} .

2. Features and Benefits

- Wide supply voltage range from 2.0 V to 6.0 V
- High noise immunity
- CMOS low power dissipation
- Latch-up performance exceeds 250 mA
- Complies with JEDEC standards:
 - JESD8C (2.7 V to 3.6 V)
 - JESD7A (2.0 V to 6.0 V)
- Input levels:
 - For EM74HC4002: CMOS level
 - For EM74HCT4002: TTL level
- ESD protection:
 - HBM ANSI/ESDA/JEDEC JS-001 Class 2 exceeds 3500 V
 - CDM ANSI/ESDA/JEDEC JS-002 Class C3 exceeds 2000 V
- Multiple package options

3. Ordering Information

Table 1. Ordering information

Type number	Package		
	Name	Description	Quantity
EM74HC4002D	SOP-14L	plastic small outline package; 14 leads; body width 3.9 mm	3000
EM74HCT4002D			
EM74HC4002PW	TSSOP-14L	plastic thin shrink small outline package; 14 leads; body width 4.4 mm	3000
EM74HCT4002PW			

4. Function Diagram

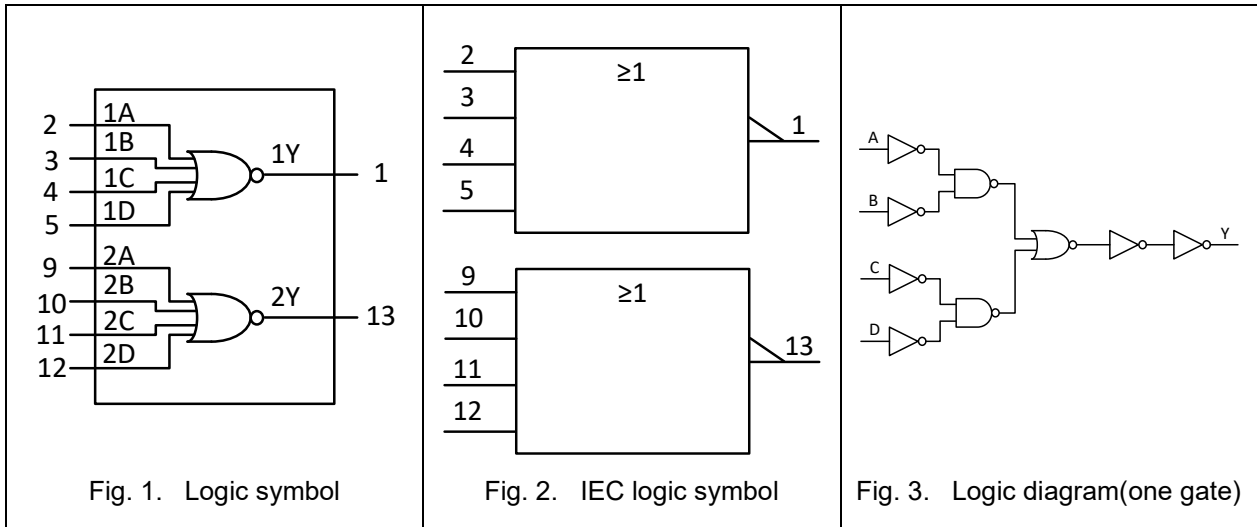

5. Pinning Information

5.1. Pinning

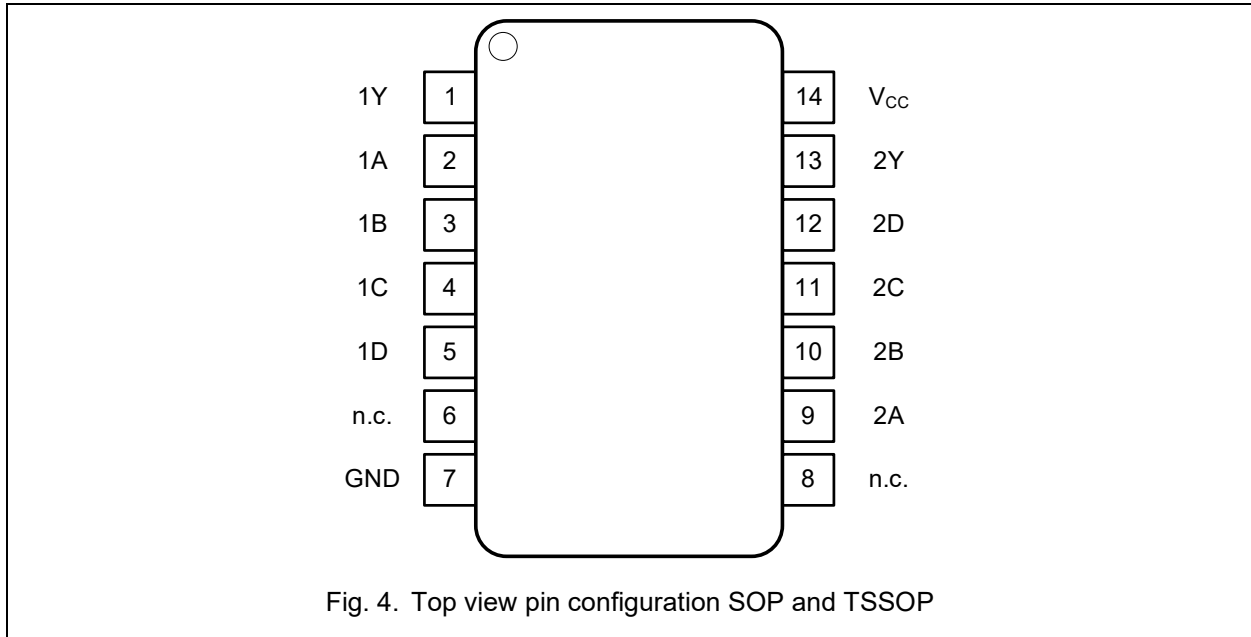

5.2. Pin description

Table 2. Pin description

Symbol	Pin	Description
1A, 1B, 1C, 1D	2, 3, 4, 5	Data input
2A, 2B, 2C, 2D	9, 10, 11, 12	Data input
1Y, 2Y	1, 13	Data output
GND	7	Ground (0V)
V _{cc}	14	Supply voltage
n.c.	6, 8	Not connected