

1. General Description

The EM74HCS09 is a quad 2-input AND gate with open-drain outputs and Schmitt-trigger inputs. Schmitt trigger inputs transform slowly changing input signals into sharply defined jitter-free output signals.

2. Features and Benefits

- Wide supply voltage range from 2.0 V to 6.0 V
- High noise immunity
- CMOS low power dissipation
- Latch-up performance exceeds 250 mA
- Unlimited rise and fall times
- Complies with JEDEC standards:
 - JESD8C (2.7 V to 3.6 V)
 - JESD7A (2.0 V to 6.0 V)
- ESD protection:
 - HBM ANSI/ESDA/JEDEC JS-001 Class 2 exceeds 3500 V
 - CDM ANSI/ESDA/JEDEC JS-002 Class C3 exceeds 2000 V
- Multiple package options

EM74HCS09

Quad 2-input AND Schmitt trigger with open-drain outputs

3. Ordering Information

Table 1. Ordering information

Type number	Package		
	Name	Description	Quantity
EM74HCS09D	SOP-14L	plastic small outline package; 14 leads; body width 3.9 mm	3000
EM74HCS09PW	TSSOP-14L	plastic thin shrink small outline package; 14 leads; body width 4.4 mm	3000

4. Function Diagram

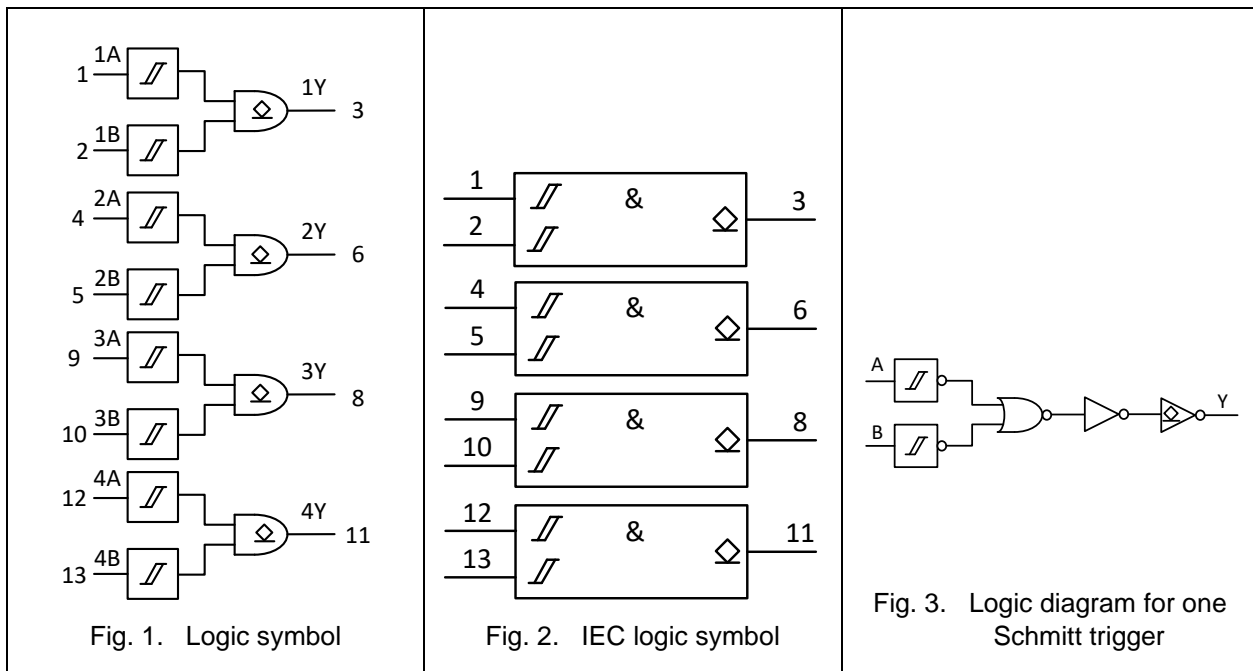

5. Pinning Information

5.1. Pinning

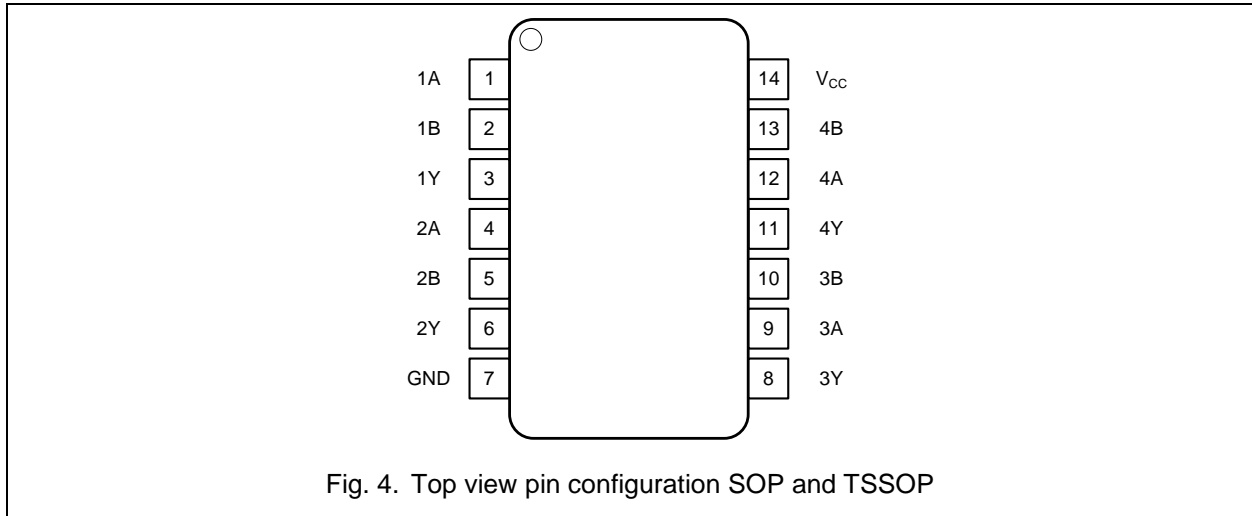

5.2. Pin description

Table 2. Pin description

Symbol	Pin	Description
1A, 2A, 3A, 4A	1, 4, 9, 12	Data input
1B, 2B, 3B, 4B	2, 5, 10, 13	Data input
1Y, 2Y, 3Y, 4Y	3, 6, 8, 11	Data output
GND	7	Ground (0V)
V _{cc}	14	Supply voltage

6. Functional Description

Table 3. Function table

H = HIGH voltage level; L = LOW voltage level.

Control		Output
nA	nB	nY
L	L	L
L	H	L
H	L	L
H	H	H