

1. General Description

The EM74HCS266 is a quad 2-input XNOR gate with open-drain outputs and Schmitt-trigger inputs. Inputs include clamp diodes. This enables the use of current limiting resistors to interface inputs to voltages in excess of V_{CC} .

2. Features and Benefits

- Wide supply voltage range from 2.0 V to 6.0 V
- High noise immunity
- CMOS low power dissipation
- Latch-up performance exceeds 250 mA
- Unlimited rise and fall times
- Complies with JEDEC standards:
 - JESD8C (2.7 V to 3.6 V)
 - JESD7A (2.0 V to 6.0 V)
- ESD protection:
 - HBM ANSI/ESDA/JEDEC JS-001 Class 2 exceeds 3500 V
 - CDM ANSI/ESDA/JEDEC JS-002 Class C3 exceeds 2000 V
- Multiple package options

EM74HCS266

Quad 2-input XNOR Schmitt trigger; open-drain output

3. Ordering Information

Table 1. Ordering information

Type number	Package		
	Name	Description	Quantity
EM74HCS266D	SOP-14L	plastic small outline package; 14 leads; body width 3.9 mm	3000
EM74HCS266PW	TSSOP-14L	plastic thin shrink small outline package; 14 leads; body width 4.4 mm	3000

4. Function Diagram

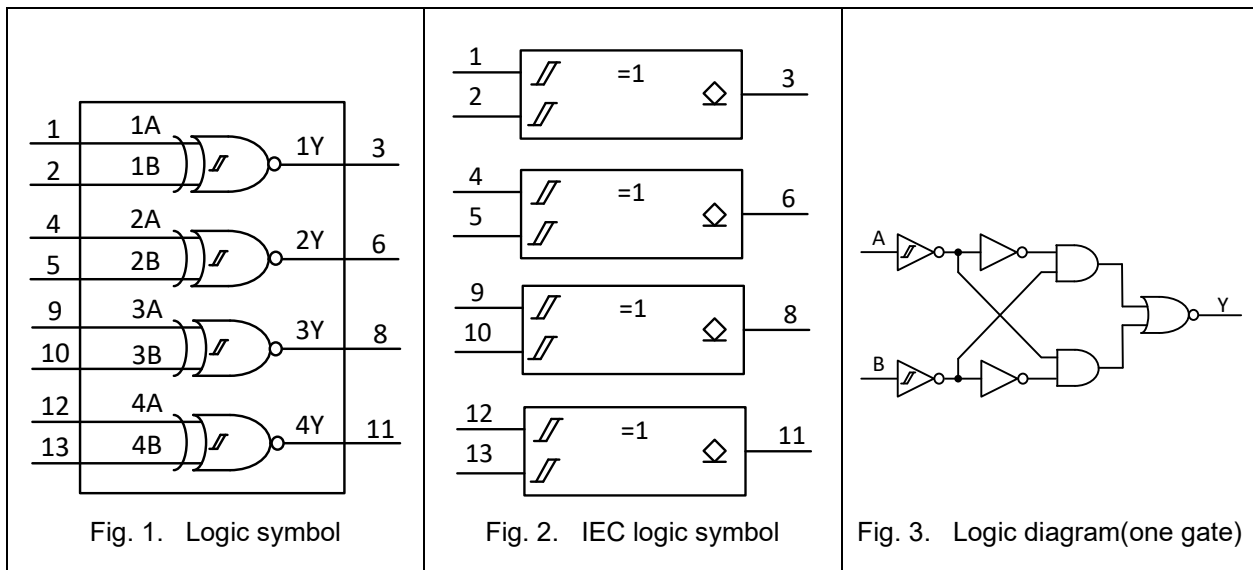

5. Pinning Information

5.1. Pinning

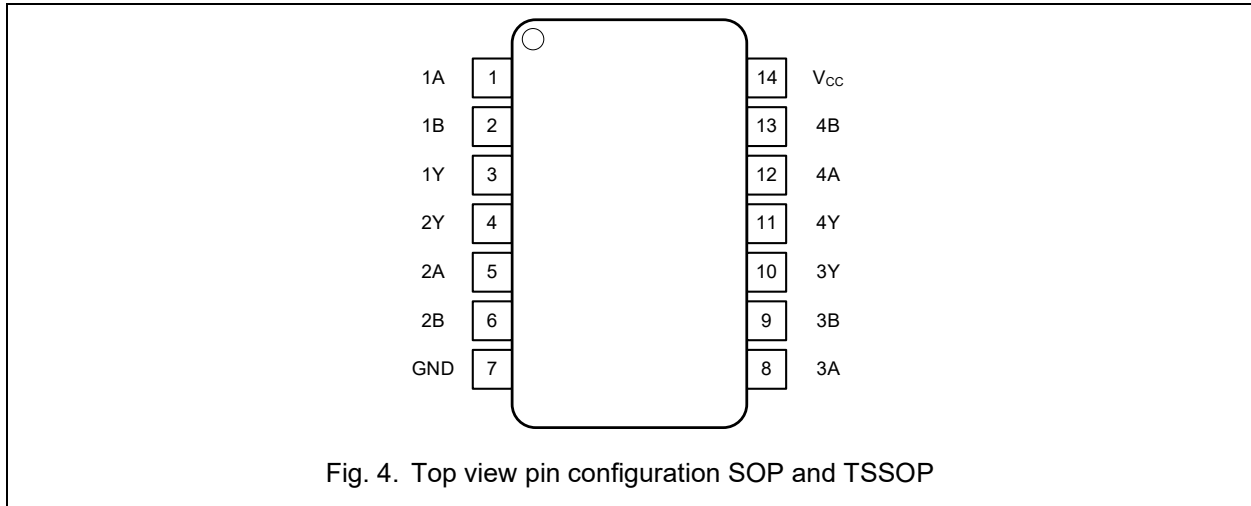

5.2. Pin description

Table 2. Pin description

Symbol	Pin	Description
1A, 2A, 3A, 4A	1, 5, 8, 12	Data input
1B, 2B, 3B, 4B	2, 6, 9, 13	Data input
1Y, 2Y, 3Y, 4Y	3, 4, 10, 11	Data output
GND	7	Ground (0V)
V _{CC}	14	Supply voltage

6. Functional Description

Table 3. Function table

H = HIGH voltage level; L = LOW voltage level; Z = high-impedance OFF-state.

Control		Output
nA	nB	nY
L	L	Z
L	H	L
H	L	L
H	H	Z